

Product range
Special lubricants for Wind Power Plants





OPTIMUM SOLUTIONS – WORLDWIDE

The two affiliates FUCHS SCHMIERSTOFFE and FUCHS LUBRITECH offer their combined expertise in the field of wind power. Both companies are wholly owned subsidiaries of FUCHS PETROLUB SE, the world's largest independent lubricant manufacturer. They offer their customers a wide range of high-performance lubricants and greases, as well as hydraulic and gear oils. The worldwide network of the FUCHS Group secures availability of the lubricants worldwide – including consulting, logistics and aftersales service.

FUCHS has the expertise to solve all lubrication-based challenges faced by wind turbine manufacturers, drive component manufacturers and also wind farm operators. No matter what lubrication tasks need to be performed in a wind turbine, FUCHS can provide exactly the right lubricant.

Two strong partners – one team



Headquarter of
FUCHS LUBRITECH in Kaiserslautern

Within the FUCHS Group, LUBRITECH is the expert for highly specialized applications. With its headquarters in Kaiserslautern, Germany and more than 500 employees worldwide, the company develops, produces and markets more than 1,000 special products, each of which is tailored precisely to its respective applications. The focus is on niche applications with maximum lubricant performance requirements and on providing outstanding technical consulting services by our lubricant experts.



Sales and technology centre of
FUCHS SCHMIERSTOFFE GMBH in Mannheim

FUCHS SCHMIERSTOFFE GMBH is a German company with more than 800 employees that develops, manufactures and markets lubricants and related specialties.

The company, founded in 1931 as RUDOLF FUCHS, has its HQ in Mannheim and operates three production facilities in Germany. Its degree of specialization and speed of innovation is far above the average for this industry. The product portfolio includes almost 2,000 different lubricants and related specialties for all walks of life, industrial processes and applications.



LUBRITECH
Special Application Lubricants



Application areas

FUCHS offers a broad product portfolio of special lubricants for all wind power applications. Many approvals of turbine, gearbox and bearing manufacturers as well as suppliers of filtering systems prove the high performance and quality of our products.

	Lubricant application	Lubricants
1	Pitch adjustment bearing	GLEITMO 585 K PLUS GLEITMO 585 K STABYL LX 460 SYN
	Tooth system	CEPLATTYN BL WHITE CEPLATTYN BL GLEITMO 585 K / GLEITMO 585 K PLUS STABYL LX 460 SYN
2	Rotor bearing	STABYL LX 460 SYN STABYL EOS E2
3	Clutch	GLEITMO 585 K / GLEITMO 585 K PLUS STABYL EOS E 2 STABYL LX 460 SYN
4	Main gearbox	RENOLIN UNISYN CLP 320 RENOLIN UNISYN XT 320 RENOLIN PENTOGEAR 320 WT GEARMASTER ECO 320
5	Generator bearings	URETHYN XHD 2
6	Yaw system reduction gear (azimuth)	RENOLIN UNISYN CLP 220 RENOLIN UNISYN XT 220 GEARMASTER ECO 220
7	Yaw system: Bearing	GLEITMO 585 K PLUS GLEITMO 585 K STABYL LX 460 SYN
	Tooth system	CEPLATTYN BL WHITE CEPLATTYN BL GLEITMO 585 K / GLEITMO 585 K PLUS STABYL LX 460 SYN
8	Hydraulic systems	ECO HYD PLUS RENOLIN UNISYN OL 32, 46 RENOLIN XtremeTemp 32, 46 RENOLIN ZAF 32 LT
	Sprocket, roller bearing	GLEITMO WSP 5040 GLEITMO 840 ECO
	Slip ring cleaner	Rivolta S.L.X. Top
	Fasteners/assembly aids	FERROFORM LOCC FERROFORM ECO LOCC
	Rapid rust removers	ANTICORIT CPX DECORDYN HF 91 DECORDYN 350
	Waxy rust-preventive	CEPLATTYN 300

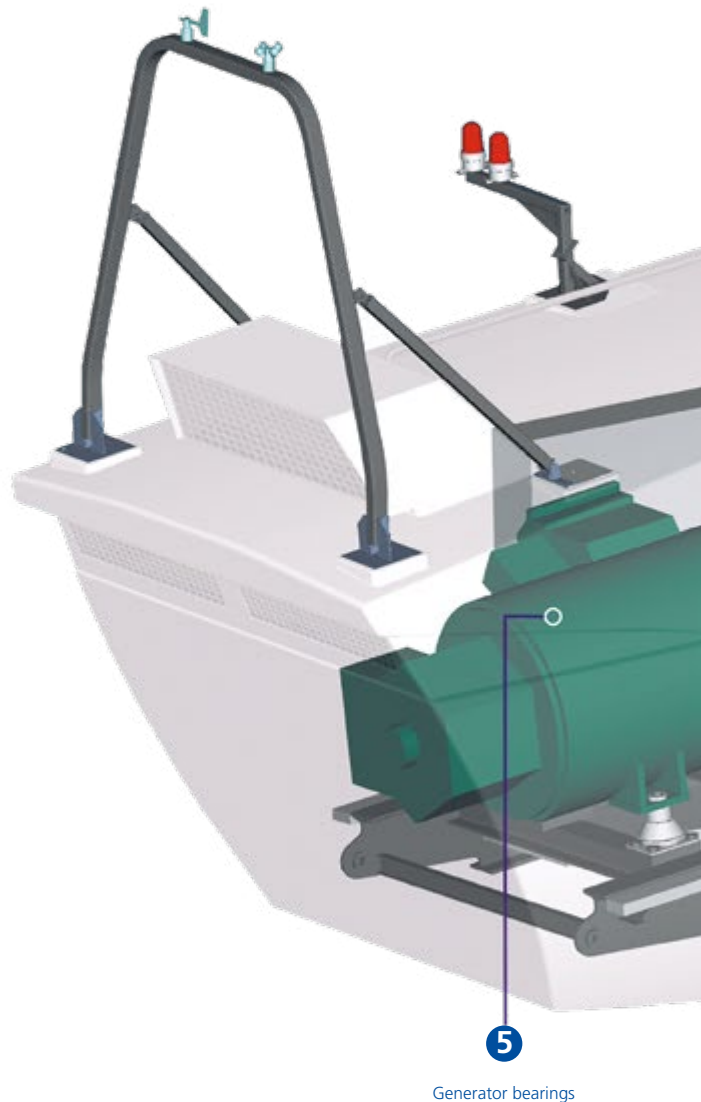

5 Generator bearings

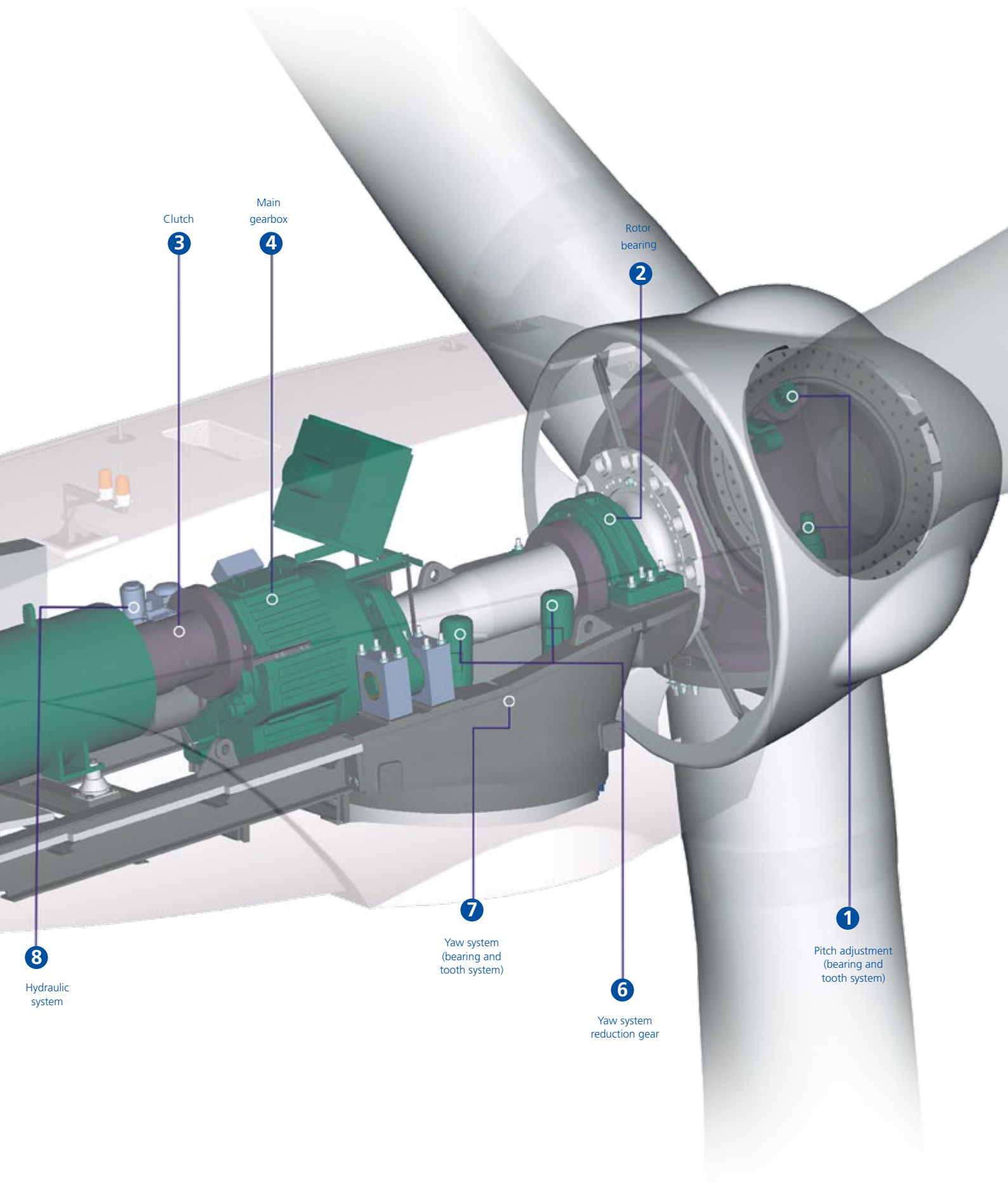

Clutch
3

Main gearbox
4

Rotor bearing
2

1

Pitch adjustment
(bearing and
tooth system)

7

Yaw system
(bearing and
tooth system)

6

Yaw system
reduction gear

8

Hydraulic
system

FUCHS LUBRITECH – SPECIALTY LUBRICANTS FOR THE WIND INDUSTRY

Whether in hot, cold, dry, or “aggressive” saline environments – wherever wind power stations generate energy, we do everything to ensure that no energy is lost unnecessarily. We have developed specialty lubricants for this purpose which clearly contribute to reducing the wear on your equipment and thus significantly reduce your maintenance effort and expenditures. We offer low-temperature greases for arctic conditions, high-performance greases for long-term lubrication, or efficient specialty lubricants for pitch and yaw bearings – all for ideally smooth generation of energy with no loss of energy and with optimal frictional wear protection.

Special lubricant for pitch and yaw bearings (gear ring and bearing)

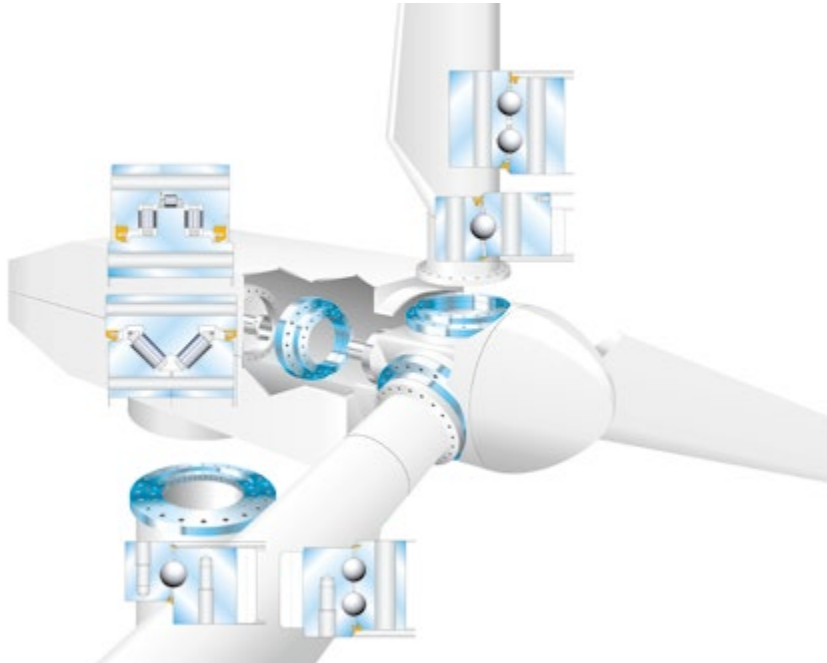

Photo: Rothe Erde

GLEITMO 585 K

GLEITMO 585 K is a well-proven, fully-synthetic special lubricant containing reactive white solid lubricants. This synergistic combination offers excellent protection against wear even under most critical operation conditions like vibrations and small oscillation movements under high load which are typical for pitch and yaw bearings of wind turbines. It is also used for gear lubrication of pitch and yaw bearings using lubrication pinions.

GLEITMO 585 K PLUS

The GLEITMO 585 K PLUS product has been developed in order to meet the requirements of novel lubrication systems. This lubricant is most suitable where progressive distributors are used. GLEITMO 585 K PLUS was developed on the basis of the original GLEITMO 585 K and the excellent wear-protection properties have been retained despite the adaptation of the product. The PLUS in the article name stands on the one hand for the added value gained and on the other for the use in **Progressive LUbrication Systems**.

- Extremely wide temperature range, suitable for any climate condition: -45°C up to +130°C
- Consistency: NLGI grade 2
- Identification according to DIN 51502: KPFHC2K-40
- Outstanding wear protection, especially at shock loads and oscillatory movements
- Excellent protection against standstill marks, fretting corrosion and tribocorrosion
- Rippling test (TK Rothe Erde / IME at RWTH Aachen) and swivelling rippling tests (ITR at TU Clausthal) passed; prevents and protects against standstill marking
- Suitable for Individual Pitch Control with changeable swivel angle (according to comparison test of IMKT, Hanover and Fraunhofer IWES)
- Extreme Pressure (EP) properties at low rotational speed
- Approvals: Rothe Erde (ThyssenKrupp), IMO, ZS Schmieranlagen
- References: manufacturers and operators of wind power plants and component manufacturers

Fully synthetic high-performance grease for pitch, yaw and rotor bearings



Photo: Schaeffler

STABYL LX 460 SYN

STABYL LX 460 SYN is a fully synthetic high-performance grease which was especially developed for the use in wind turbines. Due to its wide operating temperature range, its high mechanical stability and its outstanding load carrying capacity, STABYL LX 460 SYN is excellently suitable for the lubrication of the main rotor bearings. Moreover, it can also be used as multifunctional grease in the very demanding lubricating areas of azimuth and pitch bearings because of its special properties. Therefore STABYL LX 460 SYN considerably reduces the necessary efforts for a safe grease supply in all these lubricating points.

- Universal application in wind turbines, especially for pitch, yaw and rotor bearings
- Extremely wide temperature range, from -40°C up to $+140^{\circ}\text{C}$
- Consistency: NLGI grade 1-2
- Identification according to DIN 51502: KPHC1-2N-40
- Reduction of lubricant diversity in wind turbines
- Excellent protection against standstill marks and fretting corrosion
- Pumpable in automatic lubrication systems
- Extreme pressure properties to protect against wear

High-performance grease for main bearings, pitch and yaw bearings

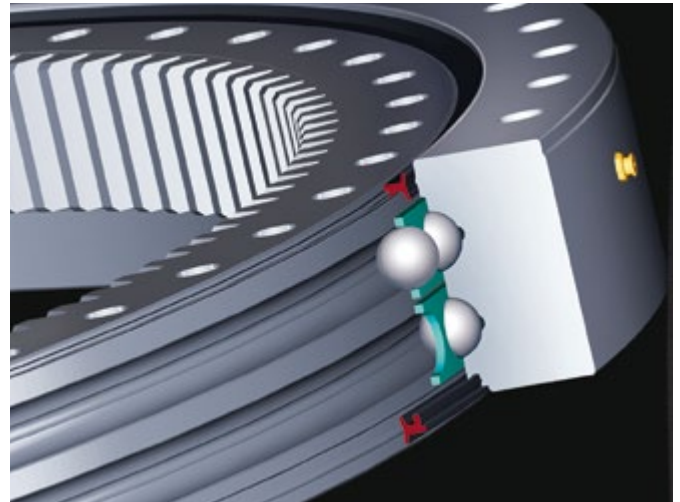

Photo: Rothe Erde

STABYL EOS E 2

STABYL EOS E 2 is a high-performance grease based on a fully-synthetic ester and a lithium soap. It fulfils the highest technical requirements for modern lubricants used in wind turbines. STABYL EOS E 2 was developed as multi-function grease in a perennial research project in cooperation with leading bearing manufacturers and is successfully in use in wind turbines as general purpose lubricant.

- Universal application in wind turbines, especially for pitch, yaw and rotor bearings
- Extremely wide temperature range, suitable for any climate condition: -45°C up to $+130^{\circ}\text{C}$
- Consistency: NLGI grade 1-2
- Identification according to DIN 51502: KPE1-2K-40
- Allows considerable reduction of lubricant diversity on wind turbines
- Very good protection against false brinelling and fretting corrosion
- Extreme pressure properties at low rotational speed
- Pumpable in automatic lubrication systems
- Approvals: Rothe Erde (ThyssenKrupp), IMO, ZS Schmieranlagen
- References: manufacturers and operators of wind power plants and component manufacturers

White adhesive lubricant suitable for low temperatures

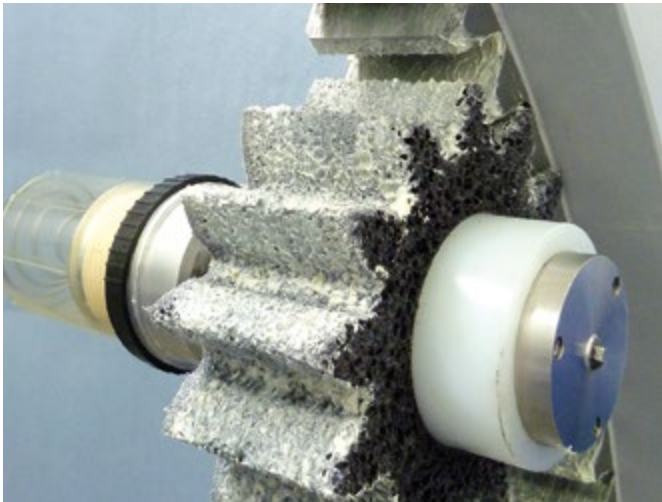

Photo: ZS Schmieranlagen

CEPLATTYN BL WHITE

CEPLATTYN BL WHITE is a white adhesive lubricant with reactive solid lubricants. It is used as a lubricant for machines and machine components operating under difficult conditions, subject to extreme temperature fluctuations and environmental influences. CEPLATTYN BL WHITE is used in particular for the lubrication of azimuth and pitch gear rings in wind turbines.

- For lubricating of azimuth and pitch gears
- Very wide temperature range: -40°C / $+160^{\circ}\text{C}$, up to $+180^{\circ}\text{C}$ for a short time, pumpable down to -30°C
- Very good adhesion to the tooth flanks
- High thermal and mechanical stability
- Protects the gear ring against corrosion
- Very good water resistance, thus also unlimited suitability for off-shore turbines
- Pumpable in automatic lubrication systems
- References: manufacturers of slewing bearings and manufacturers of lubricating equipment

Fully synthetic polyurea grease for extreme application conditions

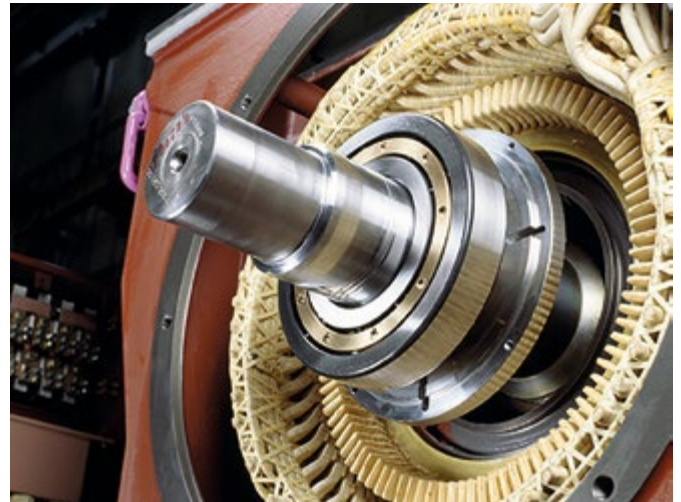

Photo: Schaeffler

URETHYN XHD 2

URETHYN XHD 2 is a soft lubricating grease with a synthetic hydrocarbon base oil and a very temperature-resistant polyurea thickener. A selected additive package provides excellent wear protection, even at fluctuating speeds, temperatures and loads.

- High-temperature lubricant for long-life lubrication of roller bearings at high temperatures, high loads, and speeds e.g. in generator bearings of wind turbines
- Temperature range: -40°C up to $+180^{\circ}\text{C}$, short-term up to $+200^{\circ}\text{C}$
- Consistency: NLGI grade 2
- Identification according to DIN 51502: KPFHC2R-40
- Extraordinary thermal stability
- High oxidation stability also during intermittent operation
- Pumpable in automatic lubrication systems
- References: manufacturers and operators of wind power plants, components and lubrication system manufacturers

Reactive white solid lubricants

Modern wind power plants must have the highest possible effectiveness in order to be able to generate electricity efficiently. Optimum design of the machine elements is required in order to achieve this over a plant lifetime exceeding 20 years. Minimizing friction in the entire system is one thing - but the avoidance of wear is even more important. Once the moving components such as roller bearings or gear wheels show initial signs of wear, this is irreversible and the service life of the components rapidly shortens.

In particular the pitch and yaw bearings in wind power plants are subject to very high requirements from a tribological point of view due to the adverse environmental conditions. Conventional greases do not provide adequate wear protection in this case. The use of solid lubricants has proven to be effective in isolating running surfaces and rolling elements from one another during static and mixed friction phases, thus preventing wear. Due to their high physio-mechanical pressure resistance these solid lubricants, unlike oils and simple greases, remain between and isolate the surfaces of the components, even under high surface pressures.

Through many years of research activities with the constant involvement of close partners from the wind power industry, FUCHS LUBRITECH has succeeded in developing a special mixture of reactive white solid lubricants. Triggered by the action of a defined load, the white solid lubricants form a protective reactive layer on the contact surfaces. This reactive layer reduces friction and above all the wear of the components of the roller bearing.

The rippling test (according to TK Rothe Erde / IME, RWTH Aachen) and swivelling rippling test (according to ITR, TU Clausthal), in which GLEITMO 585 K and GLEITMO 585 K PLUS performed very well, confirm the ideal suitability of the reactive white solid lubricants for the avoidance of bearing damage. Furthermore, GLEITMO 585 K achieved the best possible result in tests conducted by IMKT Hanover and Fraunhofer IWES for pitch bearing operation in modern Individual Pitch Control mode. The oscillating friction wear test shown below, which simulates an oscillating motion of rolling elements on bearing shells, also demonstrates the mode of action of the reactive white solid lubricants.

Oscillating friction wear test (SRV)

Surface of specimens after one hour of operation $f=50\text{ Hz}$, $A=500\text{ }\mu\text{m}$, $F=300\text{ N}$, $T=50\text{ }^\circ\text{C}$, $t=60\text{ min}$. In this test the GLEITMO pastes with reactive white solid lubricants show their outstanding performance in comparison to other products.

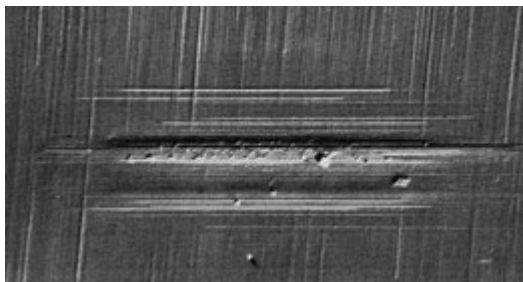

Lithium grease with MoS_2

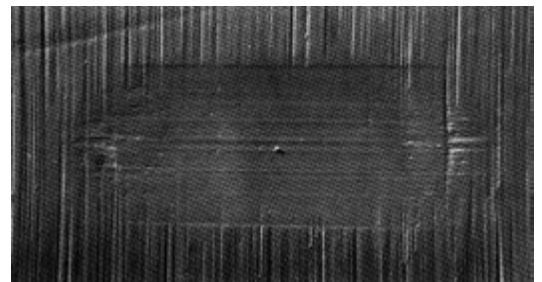
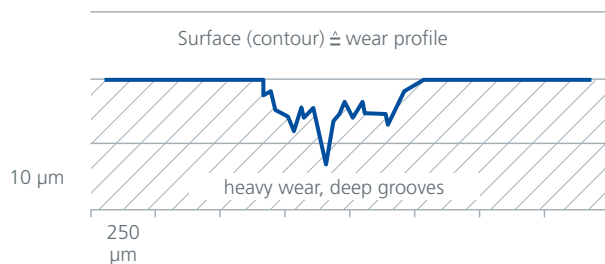

Lithium paste with reactive white solid lubricants

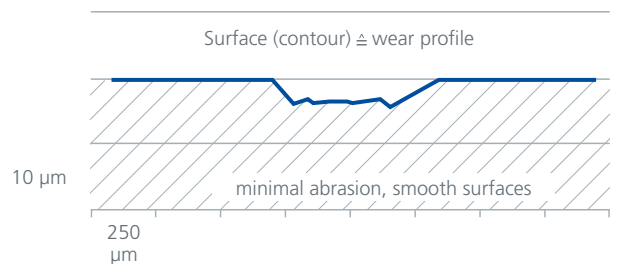

Easy and safe relubrication of wind turbines – the new service cartridge from FUCHS LUBRITECH



Service cartridge in use (screwed onto mobile case pump)



For comparison: full cartridge (left) and the completely emptied cartridge after use (right)

The maintenance of wind power plants represents a big challenge for service employees. Space is at a premium at lofty heights – in addition to which the maintenance work is hampered by difficult-to-access areas. In particular the important lubrication of the individual applications and the refilling of lubrication systems can thus be very complicated. Apart from the high time expenditure there are often other adversities such as the ingress of air and dirt into central lubrication systems and applications as well as ecological aspects.

With the new service cartridge FUCHS LUBRITECH offers a solution that makes your maintenance work considerably easier, virtually eliminates the ingress of air and dirt and is also eco-friendly.

The new service cartridge has a filling volume of 4,000 ml and is simply screwed onto a mobile lubricating pump. A hose connects it with the lubricating point or a central lubrication system. The grease quantity is thus pumped directly to its destination. Since the service cartridges are filled without bubbles, the risk of air ingress is virtually excluded.

Whilst the contents of the cartridge are being pumped into the central lubrication system, your service employee can take care of other maintenance tasks. Due to the high volume of 4,000 ml, a cartridge change is often unnecessary and the risk of contamination is thus minimized. When using the corresponding case pumps, minimum switch-off via an integrated meter or a simple magnetic switch is possible.

Thanks to the special shape of the follower piston the cartridge can be almost completely emptied and is thus an extremely economical and eco-friendly solution for the relubrication of wind power plants.

Your benefits at a glance:

- Bubble-free refilling of central lubrication systems
- Low contamination risk
- Easy and time-saving handling
- Can be emptied almost completely
- Eco-friendly disposal

FUCHS SCHMIERSTOFFE – SPECIAL GEAR OILS FOR WIND TURBINES

More and more wind turbine manufacturers and operators have recognized the benefits of synthetic gear oils. With the gear oils in the RENOLIN UNISYN CLP range, FUCHS has been an exponent of these high-grade special oils for the strict requirements of wind energy plants from the very start. With several thousand installations worldwide and many gigawatts of generated energy, we have a great deal of experience in the market with our lubricants.

Special gear and lubricating oils for wind turbine gear boxes

RENOLIN UNISYN CLP

The products of the RENOLIN UNISYN CLP range are based on special fully synthetic hydrocarbons/polyalphaolefines in combination with a selected EP/AW additives and additive technology, the products guarantee excellent wear protection characteristics, good corrosion protection, high thermal/oxidative resistance and therefore a long service life with low deposit formation at the same time. In comparison with mineral oil-based products, a two-to-three-fold extension of service life can be achieved using RENOLIN UNISYN CLP.

In testing on test rigs and during wind turbine inspections, use of RENOLIN UNISYN CLP made it possible to lower the oil sump temperature in circulation systems and transmissions by approximately 5 °C to 10 °C in comparison with mineral oil-based products (low gear friction coefficients under load). Besides the reduction in temperature load on oil and components, this leads to an improvement in efficiency of up to 3%. By the reduction of the oil sump temperature the thermal / oxidative stress of the gear oil is reduced, the life time of the oil is extended and the operating viscosity is increased. With an overall rating of 1.0, RENOLIN UNISYN CLP 320 also showed impressive results in the FAG 4-stage wind turbine test (Schaeffler Group) in comparison with competitor products in the market.

It excels through its excellent wear protection characteristics in applications with differing mixed friction conditions, EHD conditions (elastohydrodynamic lubrication) and extremely high loads. Excellent results were achieved even under

the influence of water ingress. The micropitting resistance is high, as the gears in the transmission are reliably protected from this phenomenon over a wide temperature range.

Benefits with RENOLIN UNISYN CLP:

- Fully synthetic PAO-based gear oils
- Miscible and compatible with mineral oil and ester oil – facilitates the oil change
- Excellent wear protection with regard to: scuffing, bearing wear, micropitting, slow speed wear and white etching cracks
- Excellent oxidation stability
- Excellent thermal stability
- Low deposit formation
- Excellent filterability
- Low foaming tendency
- Excellent air release properties
- Excellent material compatibility
- Approvals and references:
 - ACCIONA, BOSCH REXROTH, EICKHOFF, ENERCON, FLENDER, GAMESA, GE, HANSEN, JAHNEL+KESTERMANN, LIEBHERR, SIEMENS, WINERGY, ZOLLERN, RENK, ZF and other leading gear box and wind turbine manufacturers

Gear oil in wind power plants

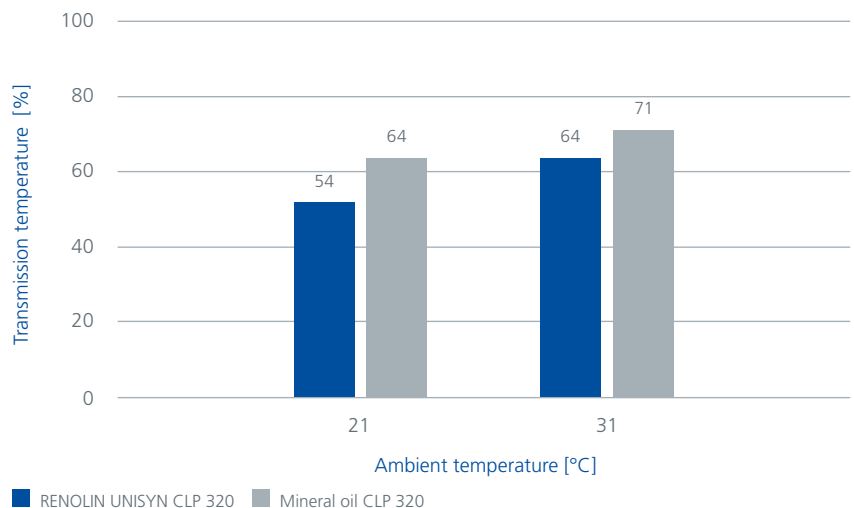

Special gear and lubricating oils for wind turbine gear boxes



Photo: ZF

RENOLIN UNISYN CLP

RENOLIN UNISYN CLP 320 is successfully used in wind turbines for years. By using a selected additive technology a robust behaviour in practice is achieved. Based on practical experiences – in combination with used oil analysis and rig tests – the excellent wear protection and corrosion protection as well as low foaming tendency and low deposit formation could have been verified.

Accessory lab testing with used oil samples from diverse wind turbines provide for an extended warranty of 7 years (and beyond – in dependence of the operating conditions). We will be pleased to provide you with further information on practical experiences, lifetime, and extended warranty.

Based on practical experiences a guideline for change-over of currently running wind turbine gear oils to RENOLIN UNISYN CLP 320 was developed. By using used oil analysis and under consideration of the condition of the wind turbine gear box it is possible to give reliable recommendations on the oil change in practice with or without flushing steps. Experiences in the field with extensive lab testing provide for an optimal and effective oil change.

Further information is available on separate info sheets:

- [Used oil analysis and lifetime](#)
- [Extended warranty for the use of RENOLIN UNISYN CLP 320](#)
- [Technical guideline for change-over to RENOLIN UNISYN CLP 320](#)

Please get in contact with us!

RENOLIN UNISYN CLP 320 – Fresh oil performance

Product performance of RENOLIN UNISYN CLP 320: Overview

Parameter / Test	Standard / Method	Conditions / Limits	Units	RENOLIN UNISYN CLP 220	RENOLIN UNISYN CLP 320	
FZG Tests	FZG Scuffing/Scoring A / 8.3 / 90	ISO 14635-1	–	Load Stage	> 12	> 14
	FZG Scuffing/Scoring A / 16.6 / 140	ISO 14635-1	–	Load Stage	12	> 12
	FZG Micropitting GFT C / 8.3 / 60	FVA 54/I-IV	–	GFT Class	High (> 10)	High (> 10)
	FZG Micropitting GFT C / 8.3 / 90	FVA 54/I-IV	–	GFT Class	High (>10)	High (>10)
FAG FE 8 - Rolling Bearing Test	Stage 1 – Rolling Elements Wear	DIN 51819-1	7.5 / 80 h / 100 KN	mg	–	< 5
	Stage 1 – Cage Wear	DIN 51819-1	7.5 / 80 h / 100 KN	mg	–	172
	Stage 2 – Rolling Elements Wear	DIN 51819-1	75 / 800 h / 100 KN	mg	–	< 5
	Stage 3 – Bearing Protection	DIN 51819-1	9000 min-1/700h/8.5KN L11	pass	–	pass - rating 1
	Stage 4 – Bearing Protection	DIN 51819-1	75 min-11600h/60KN	pass	–	pass - rating 1
SKF Bearing Test: Roller Test	Rolling Elements Wear	SKF inhouse test	8 weeks – 100°C	mg	–	2
	Changes in Viscosity of the Oil	SKF inhouse test	8 weeks – 100°C	%	–	< 5
	Sludge Formation	SKF inhouse test	8 weeks – 100°C	Grado	–	Without Sludge
	Incrustations	SKF inhouse test	8 weeks – 100°C	Yes/No	–	No
	EMCOR Test	SKF inhouse test	Dist. Water 0.5 NaCl	Rating	–	0 – no corrosion
Filtration	SKF inhouse filterability test	SKF inhouse test	< 15 min	min	–	11
	CJC Jensen Filtration Tests	CJC Jensen Method	–	–	–	Pass
	Hydac Filtration Tests	Hydac Filtration Test HN30-8	–	Rating	–	Pass

Overview test results for RENOLIN UNISYN CLP 320 in the FAG 4 stages test for wind turbine gear box oils

	Criterion	Test	Result
Stage 1*	Wear at boundary lubrication	FE8-80h	1.0 passed
Stage 2**	Fatigue behaviour at mixed friction condition	FE8-800h	1.0 passed
Stage 3***	Fatigue behaviour at EHL-condition	L11-700h	1.0 passed
Stage 4***	Fatigue behaviour and residues with water added	FE8-WKA	1.0 passed
	Summary	1.0	passed

* Tested by FUCHS report

** Tested by Assmann report

*** Tested by Schaeffler KG

RENOLIN UNISYN CLP 320 - Practical experiences

Used oil analysis for RENOLIN UNISYN CLP 320

RENOLIN UNISYN CLP 320 shows a very stable trend of kinematic viscosity and neutralisation number over a long period of time. The iron content in the oil - which gives hints on abrasive wear in the gear box - is low within the bandwidths.

RENOLIN UNISYN CLP 320 shows an excellent lubricating film stability, very good viscosity-temperature-behaviour and excellent corrosion protection and wear protection properties after 8 years of use in wind turbine main gear boxes.

Kinematic viscosity at 40°C

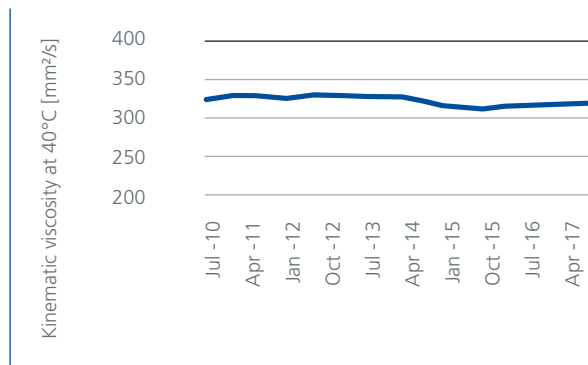

Kinematic viscosity at 100°C

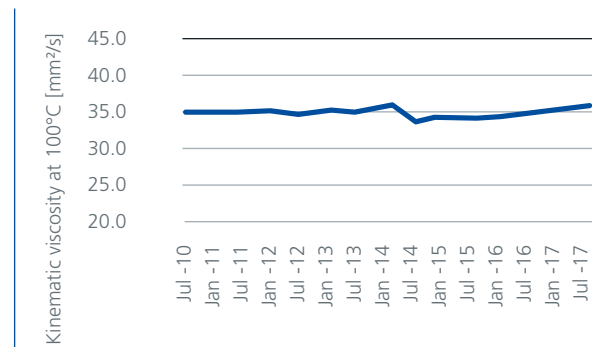

Viscosity index

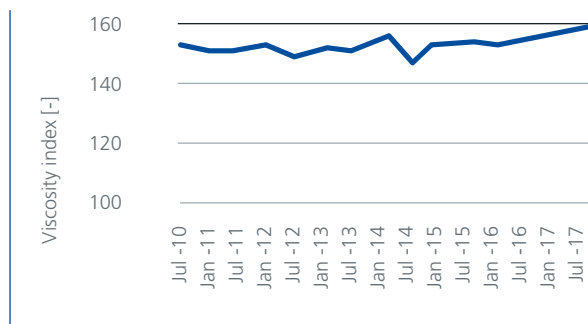

Neutralisation number

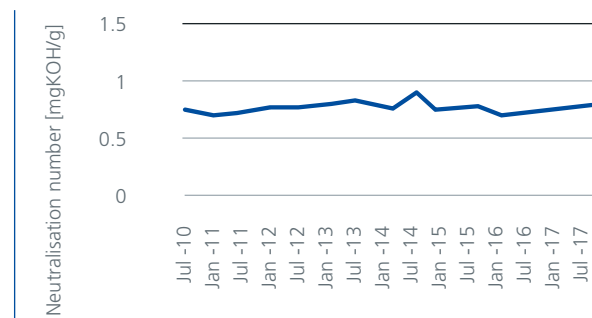

Iron content

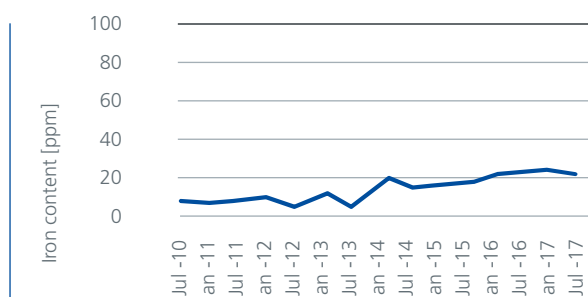

The test results of the used oil analysis prove the robust behaviour of RENOLIN UNISYN CLP 320 in main gear boxes of wind turbines of up to 8 years use!

RENOLIN UNISYN CLP 320 - Practical experiences

Even after about 35,000 operating hours RENOLIN UNISYN CLP 320 shows an excellent wear protection in the FZG test A/8.3/90 acc. to DIN ISO 14635-1.

Example wind turbine 2.4 MW
Test result with used oil sample:
Failure load stage >14 - excellent scuffing protection

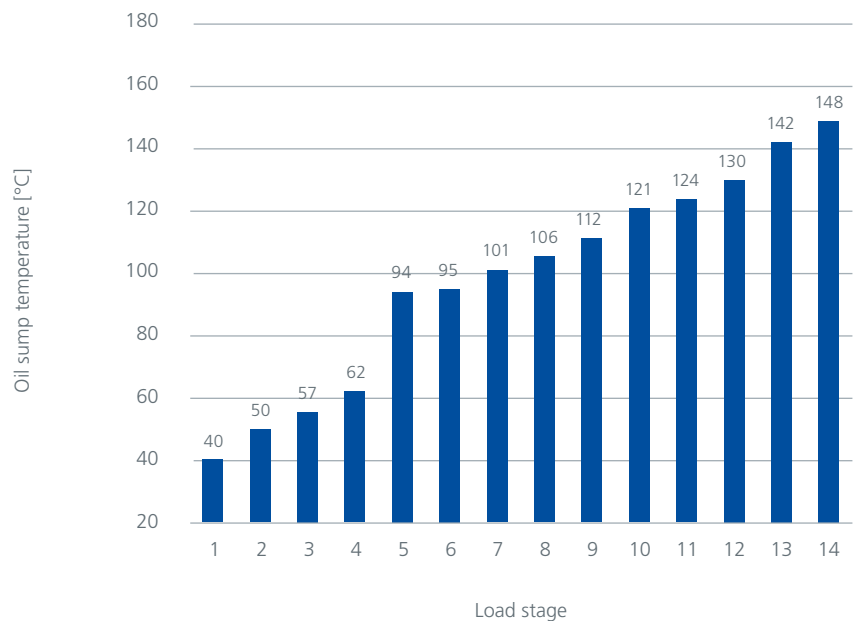

Example wind turbine 2 MW
Test result with used oil sample:
Failure load stage >14 - excellent scuffing protection

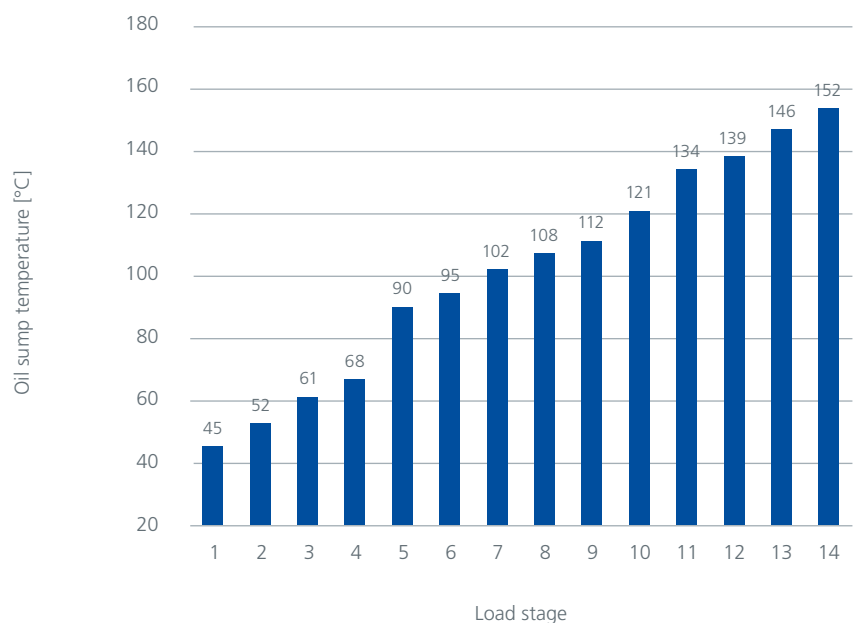

RENOLIN UNISYN CLP 320 shows excellent scuffing protection after 8 years in use!

Fully synthetic circulating and gear oils based on innovative PAO



NEW: RENOLIN UNISYN XT

With the development of the RENOLIN UNISYN XT range, FUCHS created fully synthetic circulating and gear oils based on the latest technology. In the products of the RENOLIN UNISYN XT range, innovative PAO base oils are combined with a special EP/AW additive technology. The use of innovative PAO grades in particular allows the benefits of a much wider operating temperature range compared to conventional PAO-based circulating/gear oils, while also improving low-temperature flow characteristics. They therefore offer significant advantages in terms of starting behavior at low temperatures when compared with conventional PAO grades.

The products in the RENOLIN UNISYN XT range boast a high natural and shear-resistant viscosity index of around 180. In addition to this, the RENOLIN UNISYN XT oils offer increased aging stability, good load-carrying capacity and reliable wear protection for roller bearings and gears in wind turbine transmissions. Thanks to their high micropitting resistance, they offer reliable protection from this phenomenon over a wide temperature range.

RENOLIN UNISYN XT 320 has been tested in the FAG 4-stage wind turbine test (Schaeffler Group) and has shown excellent results with an overall rating of 1.0.

- Fully synthetic gear oils based on innovative PAO
- Miscible and compatible with mineral oil, ester oil and conventional PAO gear oils
- Micropitting resistance „high“, reliable protection
- Micropitting, failure load stage: LS > 10 at both 60 °C and 90 °C
- FZG scuffing load capacity, high degree of protection, FZG A/8.3/90, failure load stage >14, FZG A/16.6/90, failure load stage >14
- FAG 4-stage wind turbine test, overall rating 1.0 (excellent wear protection characteristics)
- FE 8 roller bearing wear test 7.5/80/80: roller bearing wear 1.0 mg, 7.5/100/80: roller bearing wear 7 mg (excellent wear protection characteristics)
- WEC test (white etching cracks) as per FE 8 pitting test VW-PV-1483, no WEC damage (high degree of protection)
- Excellent low-temperature behavior
- Low foaming tendency
- Good air release properties
- Very good aging stability

RENOLIN UNISYN XT has a better start-up behavior and cold flow properties due to excellent low temperature viscosities

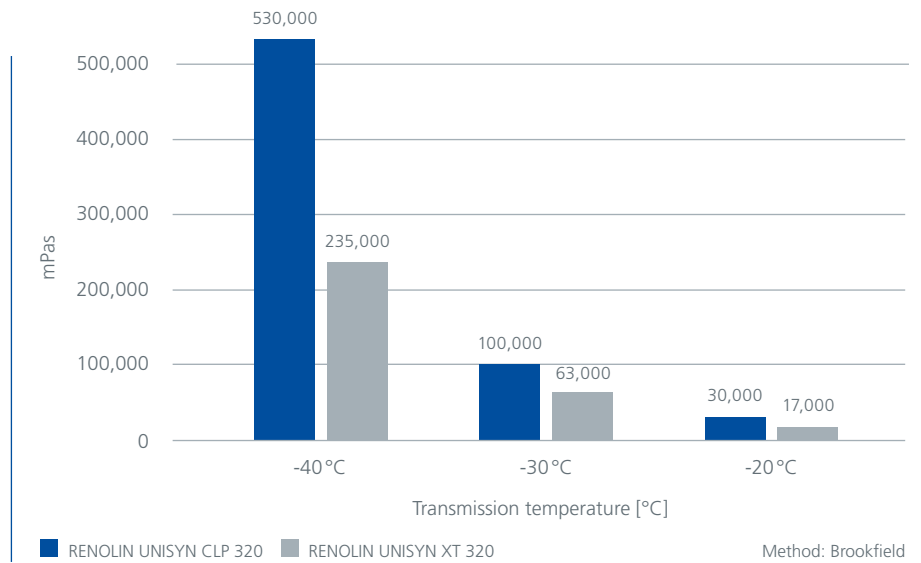

- Very good corrosion protection
- Excellent viscosity-temperature behavior
- Very high natural shear-resistant viscosity index (VI around 180)
- Multigrade characteristics
- Excellent wear protection, high scuffing load carrying capacity
- For high-temperature and low-temperature applications
- RENOLIN UNISYN XT is approved by SIEMENS FLENDER, BOCHOLT, table A 7300

At operation temperatures RENOLIN UNISYN XT shows a better stability of the lubrication film

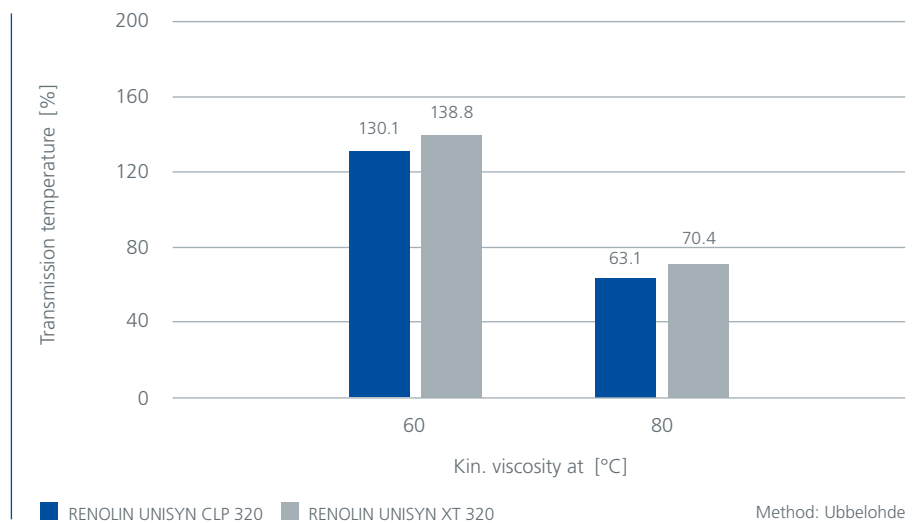

PAO-free high-performance gear oil based on innovative base oil technology for gears / roller bearings



RENOLIN PentoGear 320 WT

With RENOLIN PentoGear 320 WT, FUCHS developed a PAO-free wind turbine gear oil with innovative base oil technology. RENOLIN PentoGear 320 WT is formulated by the use of special polymers and hydrated base oils. Its use as a high-performance gear oil is recommended for all wind turbine installations, particularly in the service segment. In developing RENOLIN PentoGear 320 WT, a major focus lay on good miscibility with the industrial gear oils commonly used in the market. The use of innovative base oils, together with a matched additive system, allows excellent performance to be achieved.

RENOLIN PentoGear 320 WT displays excellent wear protection, both for gears and roller bearings. In addition to this, RENOLIN PentoGear 320 WT displays good corrosion protection (steel and copper) and good compatibility with the seals and coatings used in wind turbines. Field tests have demonstrated that the product is capable of reducing the oil temperature in heavy duty bearings.

In real-world applications, RENOLIN PentoGear 320 WT was able to demonstrate its robust operating performance, excellent foaming behavior and very low deposit formation.

- PAO-free gear oil, based on innovative base oils, which delivers very good technical performance
- Miscible and compatible with mineral oil, PAO oil and ester oil
- Micropitting resistance "high", failure load stage: LS >10 at both 60°C and 90°C
- FZG scuffing load capacity, high degree of protection
- FZG A/8.3/90, failure load stage >14
- FZG A/16.6/90, failure load stage >12
- FE 8 roller bearing wear test 7.5/8/80: roller bearing wear 3 mg (very good wear protection characteristics)
- Good miscibility/compatibility with mineral oil-based and PAO-based industrial gear oils
- Good compatibility with seals and coatings
- Lowest deposit formation, robust operating performance
- Good foaming behavior
- Combination of polar and non-polar base oil components, „low varnish oil“
- RENOLIN PentoGear 320 WT is approved by FLENDER, BOCHOLT, table A 7300

Environmentally friendly circulating and gear oils based on synthetic, fully saturated esters



Gear before the change over to GEARMASTER ECO 320

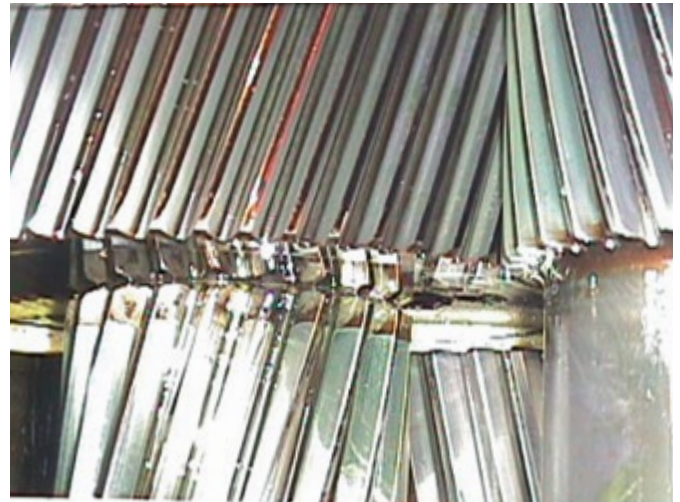

Gear after the change over to GEARMASTER ECO 320

GEARMASTER ECO 320

GEARMASTER ECO 320 are environmentally friendly high-performance industrial gear oils based on synthetic, fully saturated esters. Using its decades of experience and its position as market leader in the field of biodegradable and biogenic (as per CENTR 16227), FUCHS developed and successfully established a gear oil in the market that meets the strict transmission lubrication requirements of wind turbines, while at the same time protecting the environment and making a major contribution to resource conservation.

GEARMASTER ECO 320 gear oils are based on polar synthetic saturated ester oils. Thanks to the raw materials selected, they offer a very good wetting capacity and outstanding cleaning properties (Clean Gear Technology).

GEARMASTER ECO was awarded the EU Ecolabel.

EU Ecolabel: GEARMASTER ECO 320: DE/027/214



Better for the environment ...

- geringfügige Schädigung von Wasser und Boden bei der Anwendung
- enthält einen großen Anteil von Ausgangsstoffen auf biologischer Basis
- reduced harm for water and soil during use
- contains a large fraction of biobased material

... better for you.

GEARMASTER ECO 320 excels through its excellent corrosion protection, as well as high temperature and oxidation stability. Low friction coefficients mean that gear oil temperatures can be reduced and efficiency increased. GEARMASTER ECO 320 also boasts a high scuffing load carrying capacity and high micropitting resistance over a wide temperature range.

- Fully synthetic biodegradable gear oil based on fully saturated synthetic esters
- Very good oxidation stability
- Excellent thermal stability
- Excellent wetting and cleaning properties - „Clean gear technology“
- Very good wear protection
- Biodegradable acc. to OECD 301 C > 60%
- High percentage of renewable resources
- Awarded the EU Ecolabel

White etching cracks

New mechanical tests for industrial gear oils

WEC – white etching cracks

Over the last few months and years, there have been more and more discussions on failures of roller bearings, gear teeth and gear boxes as a result of the damage phenomenon known in the market as “white etching cracks”.

The damages which have occurred in practice led to this question:

to what extent do certain additives and gear oil formulations prevent or promote white etching cracks in roller bearings and gears?

This in turn led to the development of a roller bearing bench test, as these machine elements are particularly susceptible to the WEC phenomenon. The FE8 pitting test as per VW-PV-1483 was used to investigate WEC. The test was performed on axial cylinder roller bearings with an axial load of 60 kN at speeds of 350 and 750 rpm, at an oil temperature of 100 °C and an oil flow rate of 2 x 0.1 l/min.

The fatigue life of the bearing and the influence of the oil formula are determined and the occurrence of the WEC damage on the cylinder raceway or cylinder roller is evaluated.

An API GL4 manual transmission oil was defined as the low reference oil and used to generate WEC damage on the roller bearing raceway.



Among others, RENOLIN UNISYN CLP and RENOLIN UNISYN XT were used as high reference oils. With the RENOLIN UNISYN CLP 100 and RENOLIN UNISYN XT 100 high reference industrial gear oils, a test duration of > 9 million revolutions was reached in this roller bearing test without any WEC-type damage occurring.

RENOLIN gear oil formulations were also tested in combination with various anticorrosion oils, metal working fluids and critical additive components. The robustness of the formulation displays excellent wear protection characteristics and optimum protection with regard to the white etching cracks phenomenon.

Gear oils

Series RENOLIN UNISYN CLP*

Description: Fully-synthetic gear and circulating oils with excellent thermal and ageing stability, very high viscosity index, outstanding low-temperature behaviour, very good cold-flow-properties, excellent air release and low foaming tendency, good micropitting resistance, excellent FE8 performance, good demulsibility. The oils of the RENOLIN UNISYN CLP series surpass the minimum requirements on gear oils CLP-HC acc. to DIN 51517-3, ISO 6743-6 and ISO 12925-1: CKC, CKD, CKE, AISE 224, David Brown S1.53.101.

Application: For the lubrication of bearings and gearboxes with high thermal loads. RENOLIN UNISYN CLP oils are also suitable for lubricated-for-life applications and for the use in gearboxes with extended oil change intervals. Excellent low-temperature characteristics, high, shear stable viscosity index. Approved by leading gear box manufacturers.

- RENOLIN UNISYN CLP 320 for the use in main gear boxes in wind turbines.
- RENOLIN UNISYN CLP 220 for the use in pitch systems in wind turbines.

Product name	Density at 15°C [kg/m³]	Flash point Clev. [°C]	Kinematic viscosity, [mm²/s]		VI Viscosity index	Pourpoint [°C]
			at 40°C	at 100°C		
RENOLIN UNISYN CLP 220	854	260	220	26.7	155	-42
RENOLIN UNISYN CLP 320	860	260	320	35	155	-42

NEW: Series RENOLIN UNISYN XT*

Description: Fully-synthetic industrial gear oils based on new, innovative polyalphaolefins with very high, natural, shear stable viscosity index and excellent low temperature behaviour. Excellent wear protection, high micropitting resistance. RENOLIN UNISYN XT oils exceed the requirements on industrial gear oils CLP-HC acc. to DIN 51517-3, ISO 6743-6, ISO 12925-1: CKC, CKD, CKE and AGMA 9005/E02: EP.

Application: For the use in applications with high requirements on wide temperature range. Approved by leading gearbox manufacturers.

- RENOLIN UNISYN XT 320 for the use in main gear boxes in wind turbines.
- RENOLIN UNISYN XT 220 for the use in pitch systems in wind turbines.

Product name	Density at 15°C [kg/m³]	Flash point Clev. [°C]	Kinematic viscosity, [mm²/s]		VI Viscosity index	Pourpoint [°C]
			at 40°C	at 100°C		
RENOLIN UNISYN XT 220	860	242	220	29.4	174	-42
RENOLIN UNISYN XT 320	860	242	320	40.2	179	-42

RENOLIN PentoGear WT

Description: PAO-free industrial gear oil based on innovative base oil technology for main gear boxes in wind turbines. Excellent wear protection, good miscibility and compatibility with mineral oil based or synthetic gear oils based on PAO or esters. Reduces the operating temperatures of highly-loaded bearings. Due to the use of polar and unpolar components the formulation provides a very low deposit formation (low-varnish-oil).

Application: For the use in main gear boxes of wind turbines.

Further ISO VG classes available on request.

Product name	Density at 15°C [kg/m³]	Flash point Clev. [°C]	Kinematic viscosity, [mm²/s]		VI Viscosity index	Pourpoint [°C]
			at 40°C	at 100°C		
RENOLIN PENTOGEAR 320 WT	892	>220	320	37	165	-39

GEARMASTER ECO

Description: GEARMASTER ECO 320 is a rapidly biodegradable circulating and gear oil based on fully saturated synthetic esters with very good wear protection, corrosion protection and excellent thermal and oxidative stability. Rapidly biodegradable acc. to OECD 301 C >60%. Fulfills and surpasses the minimum requirements on gear oils acc. to DIN 51517-3: CLP-E, ISO 6743-6 and ISO 12925-1: CKC / CKD / CKE as well as AGMA 9005/E02: EP.

Application: For the use as high-performance EP industrial gear oil in main gear boxes of wind turbines. Especially for the use in environmentally sensitive areas. Approved by leading gear box manufacturers.

Product name	Density at 15°C [kg/m³]	Flash point Clev. [°C]	Kinematic viscosity, [mm²/s]		VI Viskositäts-index	Pourpoint [°C]
			at 40°C	at 100°C		
GEARMASTER ECO 320	943	280	320	35,1	155	-33

* Further ISO VG classes available

Hydraulic oils and specialities

Vickers pump test

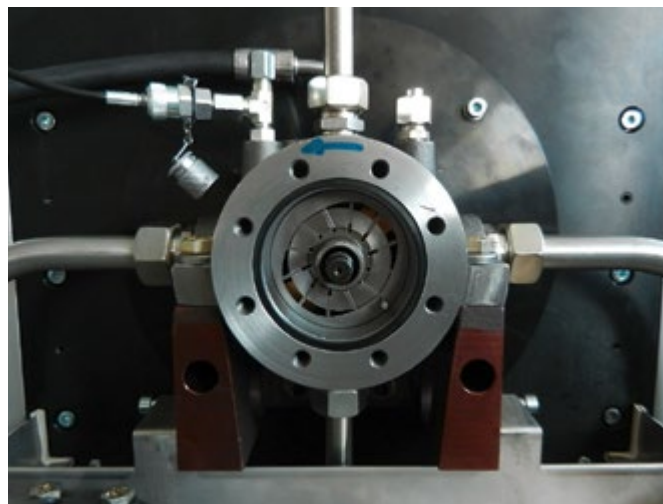

Special hydraulic fluids for wind power applications

ECO HYD S PLUS

Special hydraulic fluids for wind turbines.

Rapidly biodegradable high-performance hydraulic oil and lubricating oil based on fully saturated synthetic esters. Multigrade characteristic thanks to excellent viscosity-temperature behavior (high natural shear-stable viscosity index, VI >150). Excellent low-temperature properties, good lubricant film stability, high degree of wear protection (failure load stage >12, FZG A/8.3/90), rapidly biodegradable (>60 % as per OECD 301C). The change over guidelines acc. to ISO 15380 must be observed.

RENOLIN HVI 32 GA

Special multigrade hydraulic oil based on mineral oil.

RENOLIN HVI 32 GA is a multigrade hydraulic oil for a wide operating temperature range that was developed using special base oils.

RENOLIN HVI 32 GA has a high, shear-resistant viscosity index, VI >160. The flat curve of the viscosity-temperature characteristic guarantees good low-temperature flowability and high lubricant film stability. RENOLIN HVI 32 GA guarantees a high degree of wear protection, high stability and good corrosion protection.

Other multigrade hydraulic oils

RENOLIN UNISYN OL 32, 46

Fully synthetic hydraulic fluids based on synthetic hydrocarbons – polyalphaolefins (PAO).

These fluids boast excellent low-temperature properties (pour point <60 °C) and very good air release properties (air release = 2 mins). For extreme temperature requirements. Long lifetime.

RENOLIN XtremeTemp 32, 46

Partially synthetic hydraulic fluids based on hydrogenated hydrocarbons.

RENOLIN XtremeTemp boasts excellent low-temperature-properties (kin. viscosity at –20 °C VG 46: 2,040 mm²/s), high shear stability, excellent wear protection and a very long service life at high pressures and a high circulation index.

RENOLIN ZAF 32 LT

Zinc-free and ash-free mineral oil-based hydraulic oil with very high viscosity index, VI >280.

Excellent low-temperature behavior (pour point <–60 °C) and thereby very wide operating temperature range.

Hydraulic oils

ECO HYD S PLUS

Description: Rapidly biodegradable multigrade hydraulic oil based on special synthetic, fully saturated ester oils. Very good viscosity-temperature-behaviour due to high, shear-stable viscosity index (VI >150). Very good low temperature flowability, good lubricating film stability, high wear protection (FZG A/8.3/90: >12). Use and change-over guidelines acc. to ISO 15380 must be observed.

Application: For the use in hydraulic systems with extreme requirements on temperature and oxidation stability such as in hydraulic applications in wind turbines. Especially for the use in environmentally sensitive areas.

Product name	Density at 15°C [kg/m ³]	Flash point Clev. [°C]	Kinematic viscosity, [mm ² /s]		VI Viscosity index	Pourpoint [°C]
			at 40°C	at 100°C		
ECO HYD S PLUS	912	290	45.7	8.2	155	-36

RENOLIN HVI GA

Description: Special multigrade hydraulic oil based on mineral oils which has been developed for a high temperature range. High, shear-stable viscosity index (VI >160), good low-temperature-flowability, high lubricating film thickness at operating temperatures, high wear protection and very good filterability, even in case of water ingress.

Application: For all types of hydraulic units, especially for applications with high temperature variations and/or high loads. Especially suitable for hydraulic units in wind turbines.

Product name	Density at 15°C [kg/m ³]	Flash point Clev. [°C]	Kinematic viscosity, [mm ² /s]		VI Viscosity index	Pourpoint [°C]
			at 40°C	at 100°C		
RENOLIN HVI 32 GA	844	≥ 190	32	6.2	≥ 160	-42

Series RENOLIN UNISYN OL*

Description: Fully-synthetic hydraulic oils based on polyalphaolefins with excellent oxidation stability, outstanding wear protection, good demulsibility and excellent viscosity-temperature behaviour. High viscosity index. Excellent air release. Allow service intervals to be extended.
DIN 51524-2: HLP
DIN 51524-3: HVLP
DIN 51506: VDL

Application: For highly loaded hydraulic systems with extreme requirements on temperature and oxidation stability such as in hydraulic applications in wind turbines. Also suitable for the use in thermally stressed compressors. Oil drain intervals can be extended when oil filling is monitored.

Product name	Density at 15°C [kg/m ³]	Flash point Clev. [°C]	Kinematic viscosity, [mm ² /s]		VI Viscosity index	Pourpoint [°C]
			at 40°C	at 100°C		
RENOLIN UNISYN OL 32	838	240	32	6.1	142	<-60
RENOLIN UNISYN OL 46	843	260	46	7.9	146	<-60
RENOLIN UNISYN OL 68	845	260	68	10.6	144	-54

* Further ISO VG classes available

Hydraulic oils

Series RENOLIN Xtreme Temp

Description: Universal, high-performance hydraulic oils with high viscosity index and excellent shear stability (VI 180). Based on special hydrogenated base oils, very good ageing behavior, long lifetime, excellent corrosion protection and very good wear protection. Zinc containing AW/EP additive system.

DIN 51 524-3: HVLP
ISO 6743-4: HV
ISO 11158: HV
Bosch Rexroth
Denison HF0, HF1, HF2.

Application: Universal high-performance multigrade hydraulic oil for stationary and mobile hydraulic systems, improved efficiency, increasing oil change intervals. Multigrade characteristics through high, shear-stable viscosity index. Energy and fuel saving through high volumetric efficiency.

- Approved by Bosch Rexroth RD90235 and RDE90245

Product name	Density at 15°C [kg/m ³]	Flash point Clev. [°C]	Kinematic viscosity, [mm ² /s]		VI Viscosity index	Pourpoint [°C]
			at 40°C	at 100°C		
RENOLIN XTREME TEMP 32	845	216	32	6.9	180	-33
RENOLIN XTREMETEMP 46	853	230	48	9.3	180	-34

Series RENOLIN ZAF LT

Description: Zinc- and ash-free hydraulic oils with very high viscosity index for low-temperature applications. Demulsifying with additives to improve ageing stability and corrosion protection. Surpass the requirements acc. to DIN 51524-3: HVLP

Application: Developed for the use in applications with very low ambient temperatures in mobile and stationary equipment; latest additive technology.

Product name	Density at 15°C [kg/m ³]	Flash point Clev. [°C]	Kinematic viscosity, [mm ² /s]		VI Viscosity index	Pourpoint [°C]
			at 40°C	at 100°C		
RENOLIN ZAF 15 LT	873	>90	14	5.3	387	<-60
RENOLIN ZAF 32 LT	869	155	3	8.7	281	<-60

**Note**

The information contained in this product information is based on the experience and know-how of FUCHS SCHMIERSTOFFE GMBH / FUCHS LUBRITECH GmbH in the development and manufacturing of lubricants and represents the current state-of-the-art. The performance of our products can be influenced by a series of factors, especially the specific use, the method of application, the operational environment, component pre-treatment, possible external contamination, etc. For this reason, universally-valid statements about the function of our products are not possible. Our products must not be used in aircrafts/spacecrafts or their components, unless such products are removed before the components are assembled into the aircraft /spacecraft. The information given in this product information represents general, non-binding guidelines. No warranty expressed or implied is given concerning the properties of the product or its suitability for any given application.

We therefore recommend that you consult a FUCHS SCHMIERSTOFFE GMBH / FUCHS LUBRITECH GmbH application engineer to discuss application conditions and the performance criteria of the products before the product is used. It is the responsibility of the user to test the functional suitability of the product and to use it with the corresponding care.

Our products undergo continuous improvement. We therefore retain the right to change our product program, the products, and their manufacturing processes as well as all details of our product information sheets at any time and without warning, unless otherwise provided in customer-specific agreements. With the publication of this product information, all previous editions cease to be valid.

Any form of reproduction requires express prior written permission from FUCHS SCHMIERSTOFFE GMBH / FUCHS LUBRITECH GmbH.

Special lubricants for wind power plants

FUCHS a comprehensive service provider to the wind power industry

- Individual selection and evaluation of lubricants based on lubricant recommendations and analyses.
- Full documentation with gearbox-condition reports and recommendations.
- Reliable gear oil reports with high-accuracy oil analyses which provide specific details about oil condition and allow oil change intervals to be scheduled exactly.
- Experts support your evaluation of grease analyses out of pitch-, yaw-, main- and generator bearings.

Contact:

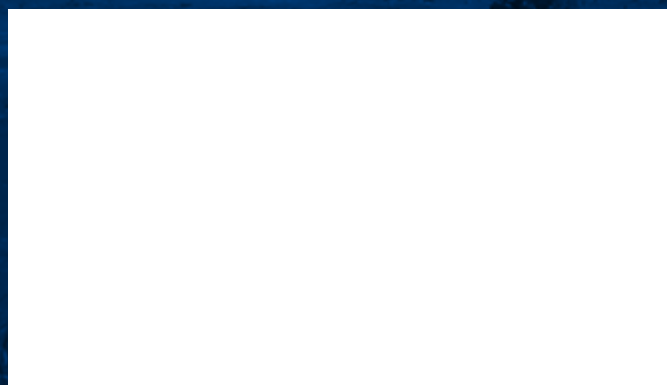

FUCHS SCHMIERSTOFFE GMBH
Friesenheimer Straße 19
68169 Mannheim/Germany
Phone: +49 621 3701-0
Fax: +49 621 3701-7000
E-mail: zentrale@fuchs-schmierstoffe.de
www.fuchs.com/de/en

FUCHS LUBRITECH GMBH
Werner-Heisenberg-Straße 1
67661 Kaiserslautern/Germany
Phone: +49 6301 3206-0
Fax: +49 6301 3206-940
E-mail: info@fuchs-lubritech.de
www.fuchs.com/lubritech